

BAIC X55 (2023-)

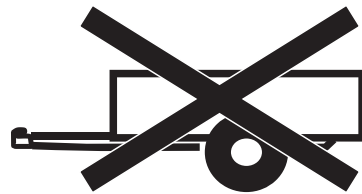
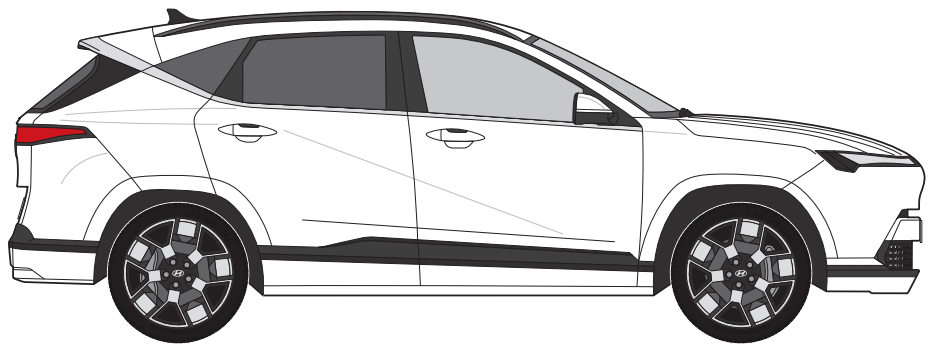

Dixi-Car Plaza

Autoryzowany Dystrybutor

ul. Malownicza 29, 02-272 Warszawa

22 716 30 20

dixi-car.pl

Nº Revisión | Fecha Aprobación
001 | 21-01-2026



BAIC X55 (2023-)

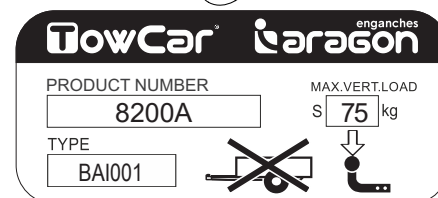
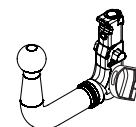

- ES** Este dispositivo ha sido diseñado y testado para soportar solamente cargas puntuales. Su uso solo es válido para transportar portabicicletas, portaequipajes o dispositivos suspendidos sobre la bola. En ningún caso y bajo ninguna circunstancia está permitido este dispositivo para remolcar. Enganches y Remolques Aragón, S.L. no se hará responsable de cualquier daño o reclamación derivada de un mal uso.
- GB** This device has been designed and tested for supporting exclusively occasional loads. Its use is suitable only for carrying bike carriers, luggage carriers or other devices fitted to the towball. It's not allowed to use this device for towing anything in any case. Enganches y Remolques Aragón, S.L. declines any responsibility or claim in case that it was not properly used.
- FR** Cet appareil a été conçu et testé pour supporter uniquement des charges ponctuelles. Son utilisation n'est valable que pour le transport de porte-vélos, porte-bagages ou autres dispositifs suspendus sur la rotule. En aucun cas et en aucune circonstance cet appareil n'est autorisé à remorquer. Enganches y Remolques Aragón, S.L. ne sera en aucun cas responsable de tout dommage ou réclamation découlant d'une mauvaise utilisation.
- IT** Questo dispositivo è stato progettato e testato per supportare esclusivamente cariche puntuali. Il suo utilizzo è valido solo per il trasporto di portabiciclette, portabagagli o dispositivi sospesi sulla sfera del gancio di traino. In nessun caso e in nessuna circostanza questo dispositivo può trainare. Enganches y Remolques Aragón, S.L. non sarà ritenuto responsabile per eventuali danni o reclami derivati da un uso improprio.
- DE** Diese Aufnahme wurde ausschließlich zum Tragen von Lasten entwickelt und getestet. Sie ist nur für die Nutzung mit Fahrradträgern, gelegentlichen Gepäckträgern oder anderen auf der Kugelkopfaufnahme montierten Vorrichtungen geeignet. Das Ziehen von Anhängern ist unter keinen Umständen erlaubt. Enganches y Remolques Aragón, S.L. übernimmt keinerlei Verantwortung oder Haftung für Schäden oder Ansprüche, die aus einer nicht bestimmungsgemäßen Verwendung resultieren.
- NL** Dit onderdeel is ontworpen en getest om uitsluitend een punctueel last te dragen. Het kan alleen gebruikt worden dragen van fietsendragers, bagagedragers of andere producten die op de trekhaak worden gemonteerd. Het is niet toegestaan om met dit product iets te trekken. Enganches y Remolques Aragón, S.L. weigert elke aansprakelijkheid of claim in het geval het product niet op de juiste wijze in gebruikt.
- TR** Bu ürün sadece ara sira yükleri taşımak için tasarlanmış ve denenmiştir. Kullanımı sadece bisiklet taşıyıcıları, bagaj taşıyıcıları, ya da çeki demirine uyumlu diğer donanımlar içindir. Bu ürünün başka hiçbir şey çekmek için kullanılmasına izin verilmemelidir. Enganches y Remolques Aragón, S.L., bu ürünün uygun olmayan şekillerde kullanılmasından doğacak hiçbir iddia ve zarar talebinden sorumlu değildir.
- GR** Αυτός ο μηχανισμός σχεδιάστηκε και ελέγχθηκε ειδικά για περιστασιακά φορτία. Χρησιμοποιείται μόνο για μεταφορά βάσεων ποδηλάτων, μπαγκαζερών και άλλων συσκευών οι οποίες εφαρμόζονται σε κοτσαδόρους. Δεν επιτρέπεται η χρήση αυτών των συσκευών για έλξη ή ρυμούλκηση σε καμία περίπτωση. Η εταιρεία ENGANCHES y REMOLQUES ARAGON S.L αποποιείται κάθε ευθύνη σε περίπτωση μη σωστής και κατάλληλης χρήσης.
- PT** Este dispositivo foi desenhado e testado para suportar somente cargas pontuais. Apenas serve para transportar bicicletas, porta bagagens ou dispositivos suspensos sobre a bola. Em caso algum e sob nenhum circunstância está autorizado para rebocar. Enganches y Remolques Aragón, S.L. não se responsabilizará de qualquer dano ou reclamação motivada por um mal uso.
- RU** Данное устройство разработано и протестировано только для случайных нагрузок. Его использование возможно только для велосипедных креплений, креплений для груза или других креплений такого рода, устанавливаемых на шар ТСУ. Использование данного устройства для буксировки какого-либо прицепа не допустимо. Компания Enganches y Remolques Aragón, S.L. снимает с себя любую ответственность при некорректном использовании данного устройства.
- PL** To urządzenie zostało zaprojektowane i przetestowane wyłącznie do przewożenia obciążeń sporadycznych, takich jak bagażniki rowerowe, kufry lub inne urządzenia dopasowane do przewożenia na haku. Niedopuszczalnym jest używanie tego urządzenia do holowania czegokolwiek. Enganches y Remolques Aragón, S.L. odrzuca wszelkie roszczenia oraz nie ponosi żadnej odpowiedzialności w przypadku nieprawidłowego użytkowania.
- CZ** Toto zařízení bylo navrženo a testováno výhradně pro podporu příležitostných nákladů. Jeho použití je vhodné pouze pro převoz nosičů kol, nosičů zavazadel a dalších zařízení upevněných na kulový čep. V žádném případě není povoleno jeho použití za účelem tažení (např. přívěsu). Enganches y Remolques Aragón, S.L. se zříká jakékoliv odpovědnosti nebo nároků v případě, bude-li zařízení nevhodně použito.

N/m	M6	M8	M10	M12	M14	M16
8,8	10	24	51	87	138	200
10,9	15	36	75	130	198	289
12,9	18	42	87	147	231	341

0 km 1000 km

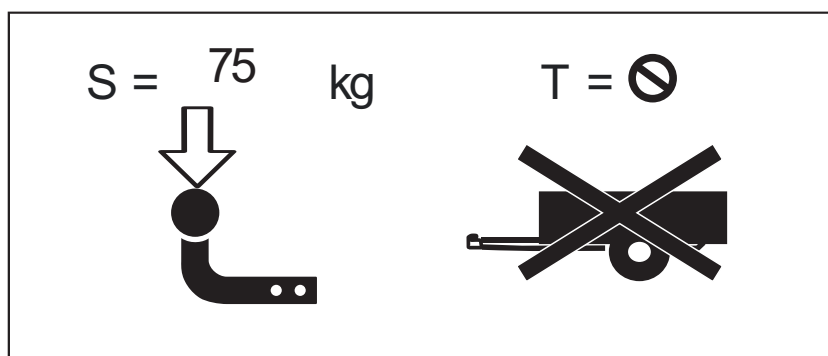

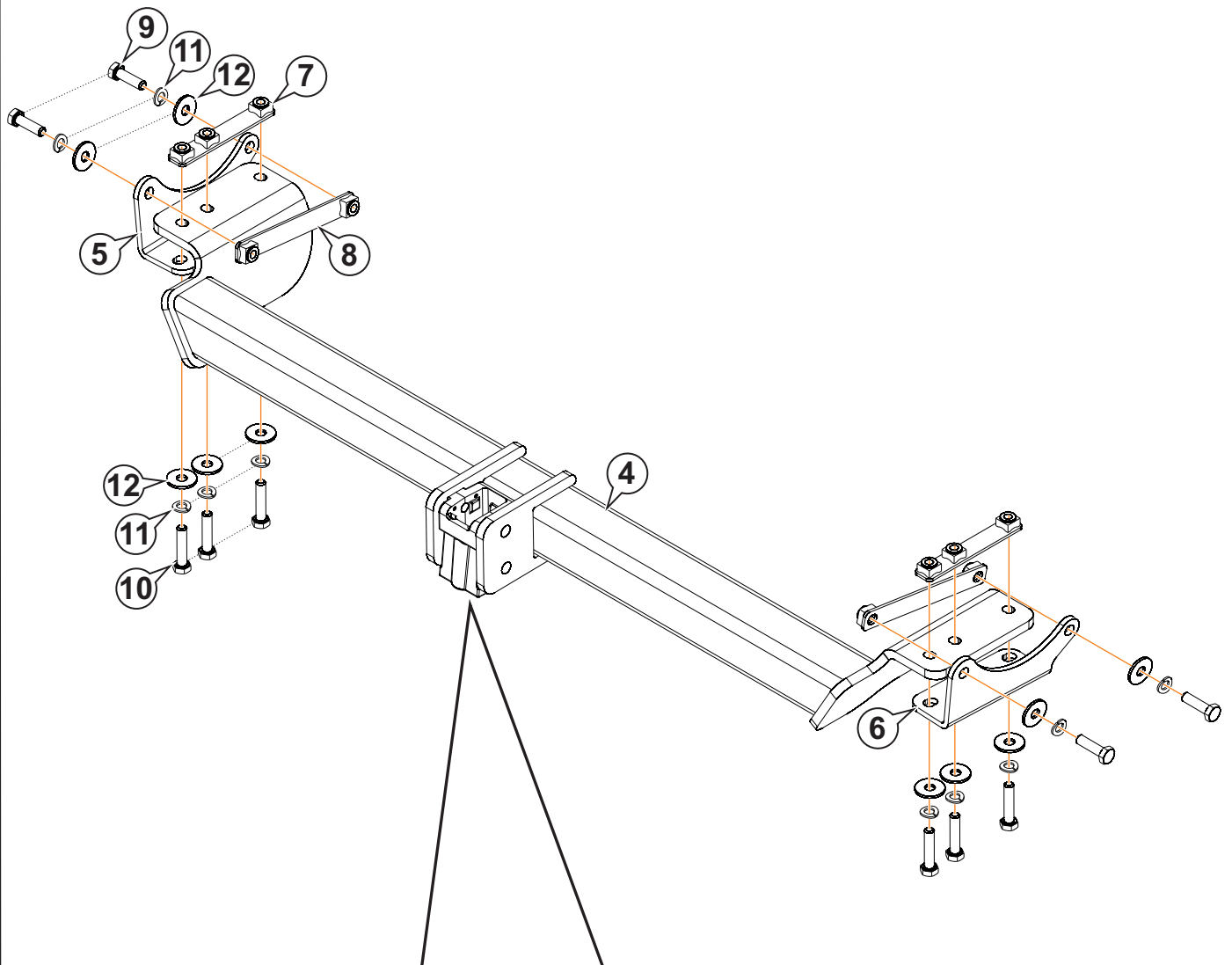

		#
F1	M12 x 25 DIN 933	3
	Ø12 Grower DIN 128	3
	M12 x 35 DIN 933	1
F2	Ø12 Grower DIN 128	1
	M6 x 25 DIN 7380	1
	Ø6 DIN 125	1
F3	Ø8 DIN 9021	1
	M6 DIN 985	1
	F4	M5 x 35 DIN 7985

M12 → Nm 87
M10 → Nm 51

(F1)	M12 (8.8)
(F2)	M12 (8.8)
(F3)	M6 (8.8)
(F4)	M5 (8.8)

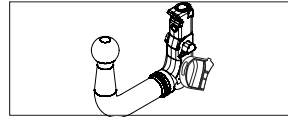

1		AEV0073	1	
2		AEV0072	1	
3		AEV0006	1	
4		C8200AV60	1	
5		C8200AV24	1	
6		C8200AV23	1	
7		C8200AV25	2	
8		C8200AV26	2	
9		M10x35 DIN 933 (8.8)	4	
10		M10x45 DIN 933 (8.8)	6	
11		Ø10 DIN 128A	10	
12		Ø10 DIN 9021	10	



1



5 min.

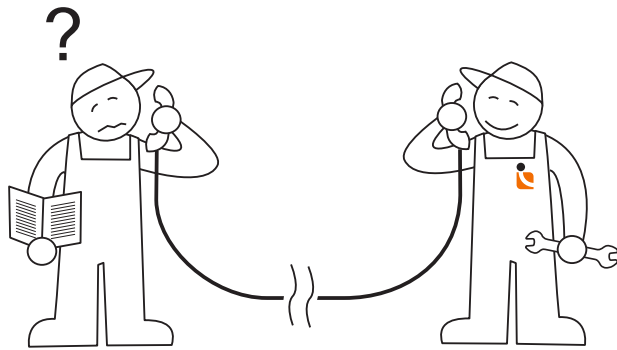

Tel.: (+34) 976 457 130

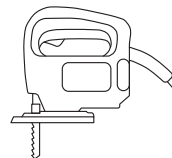
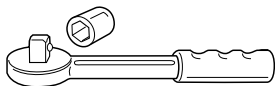
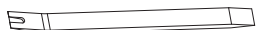

2

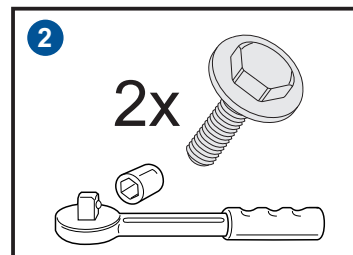
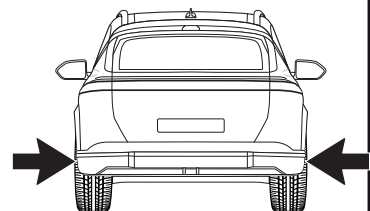
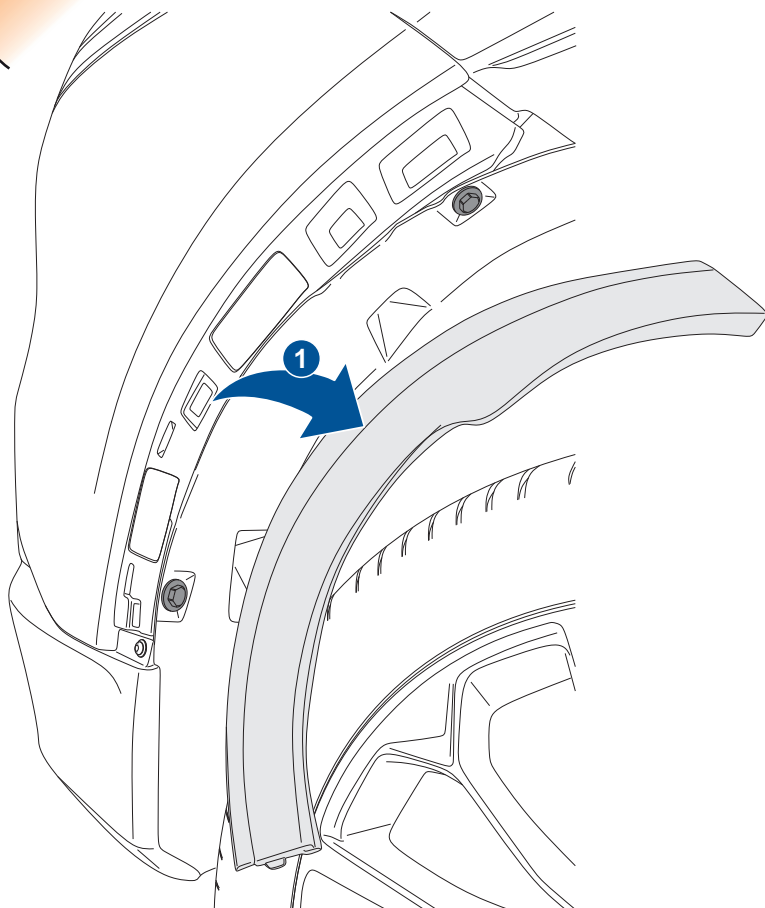



3

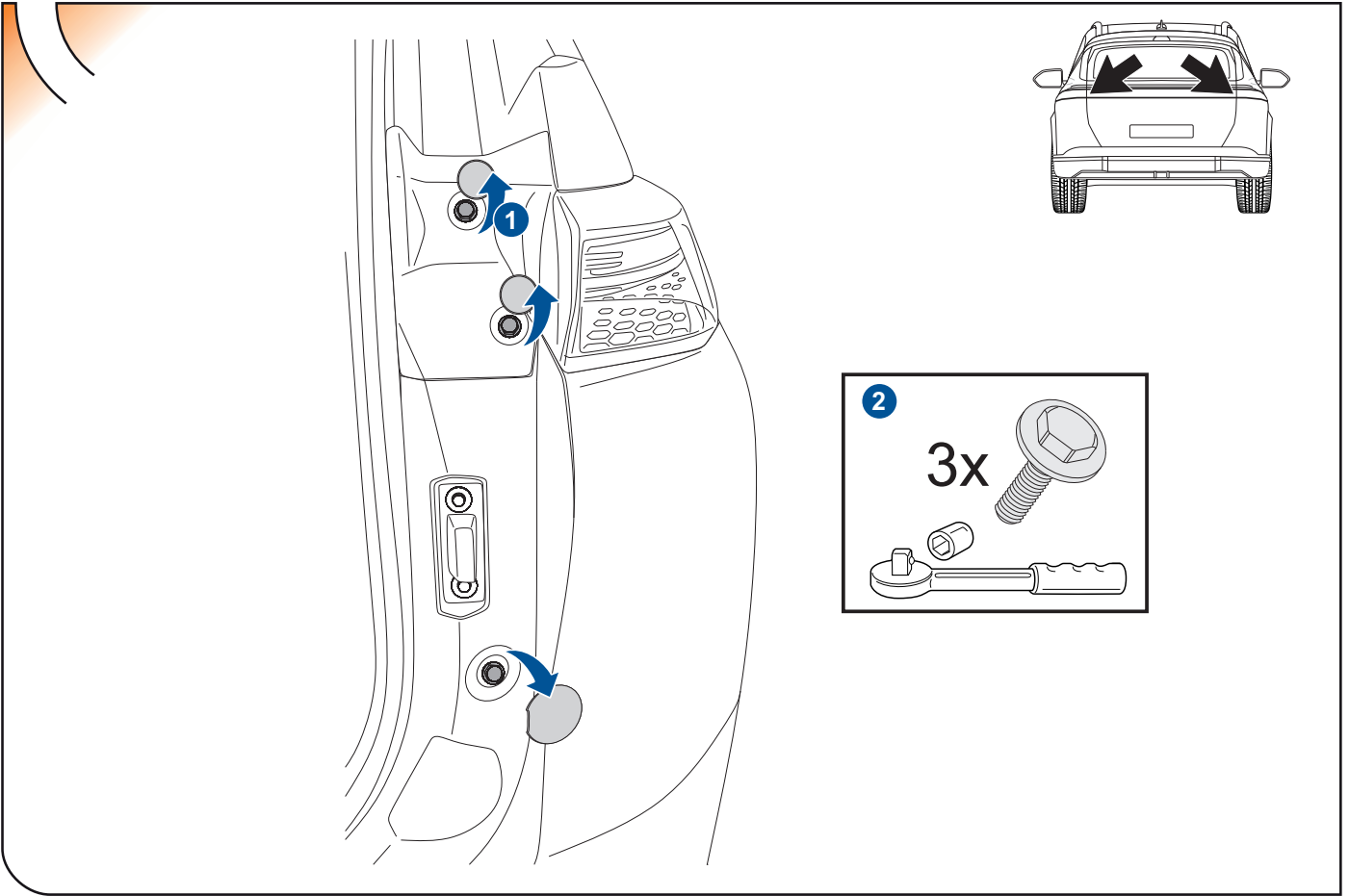

4

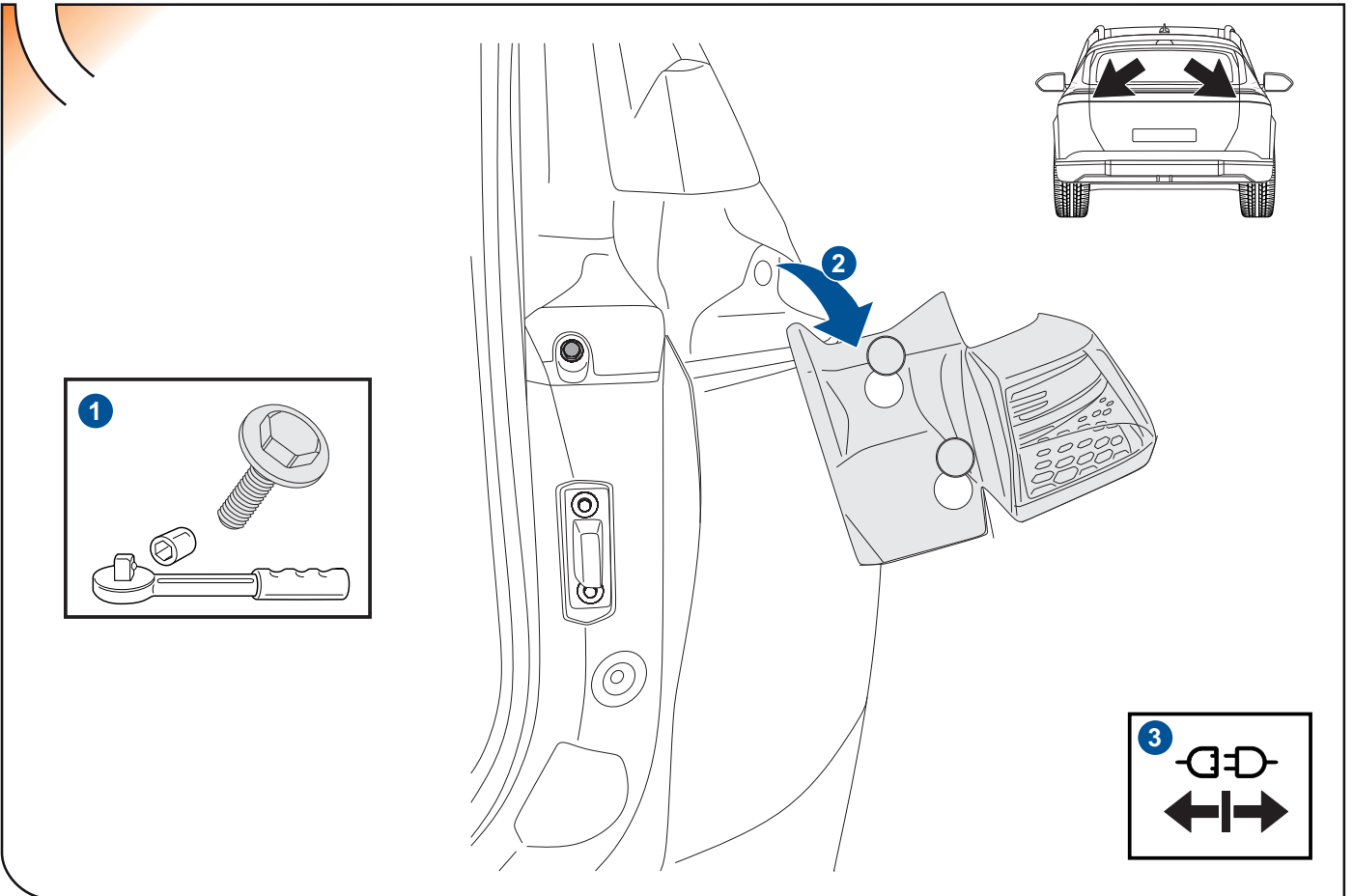



5

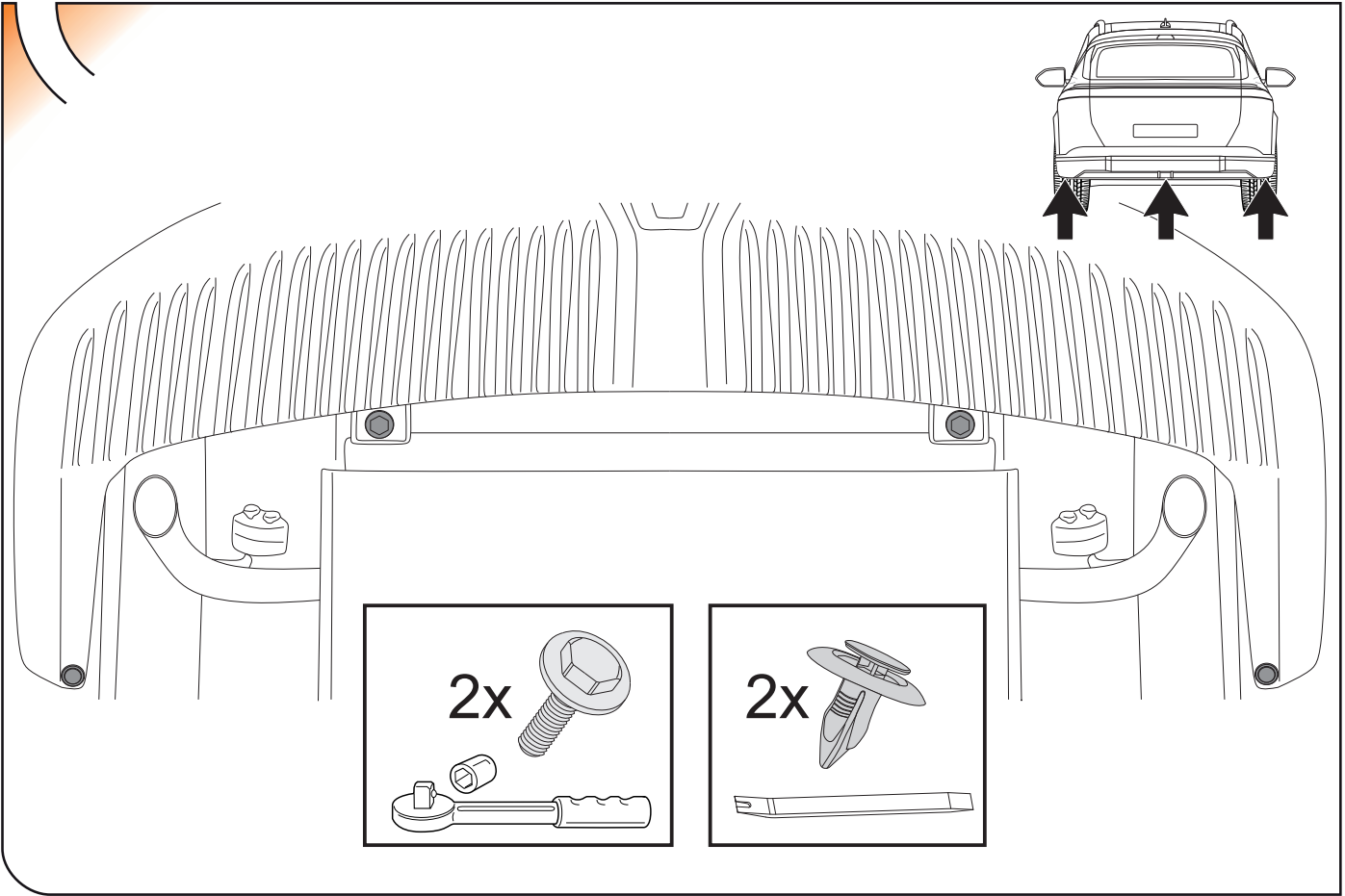

6

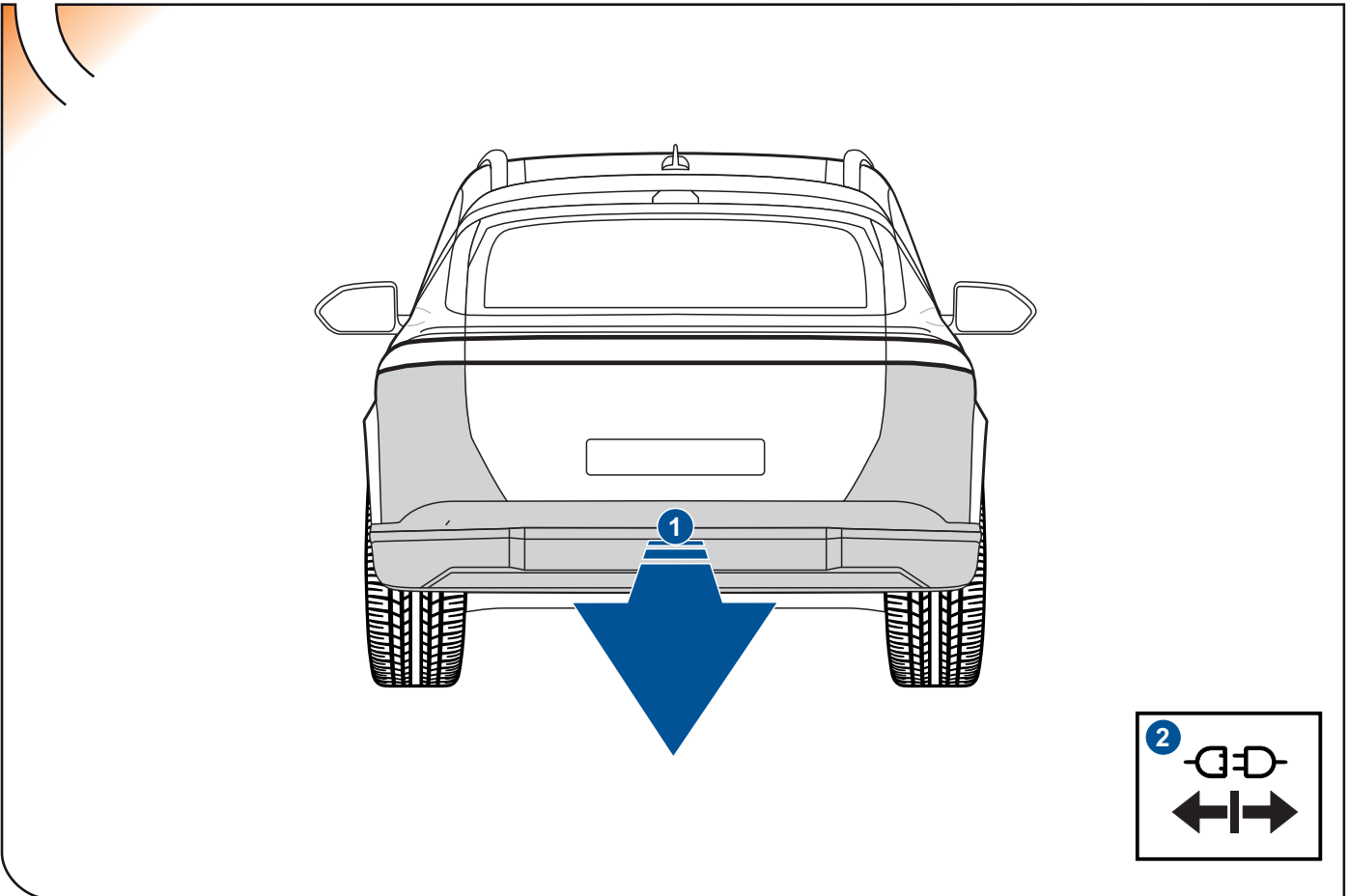



7

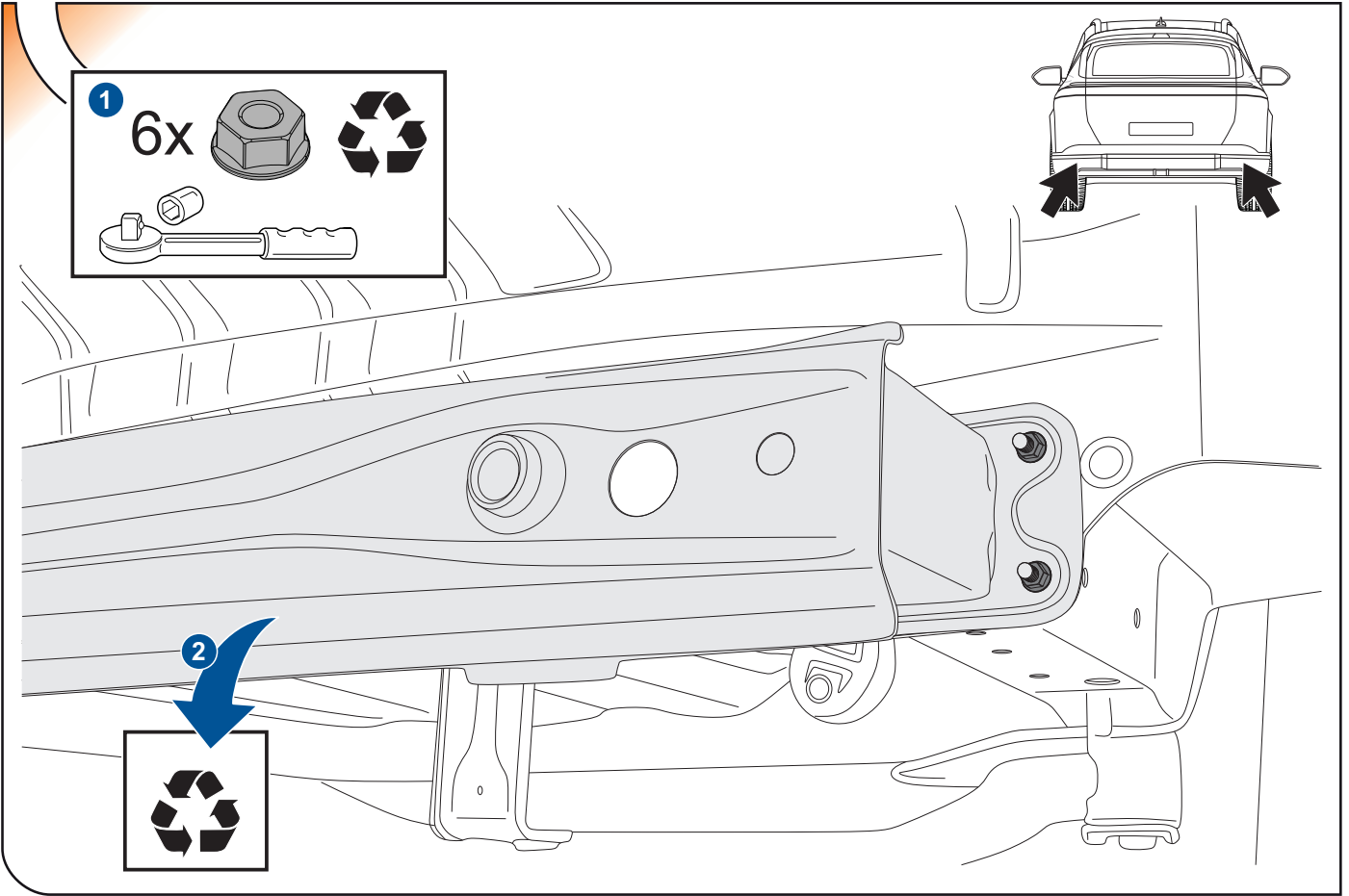

8

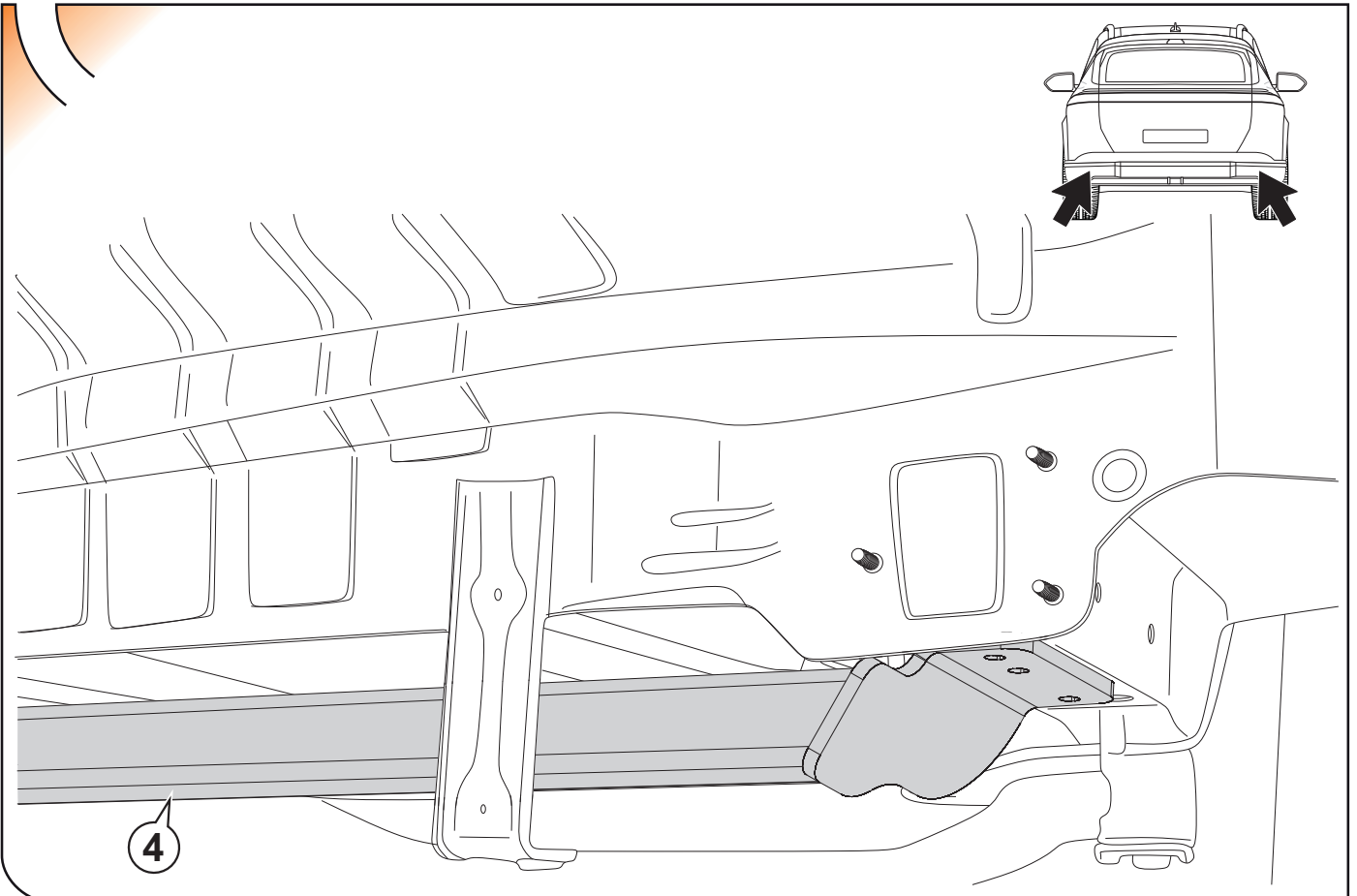



9

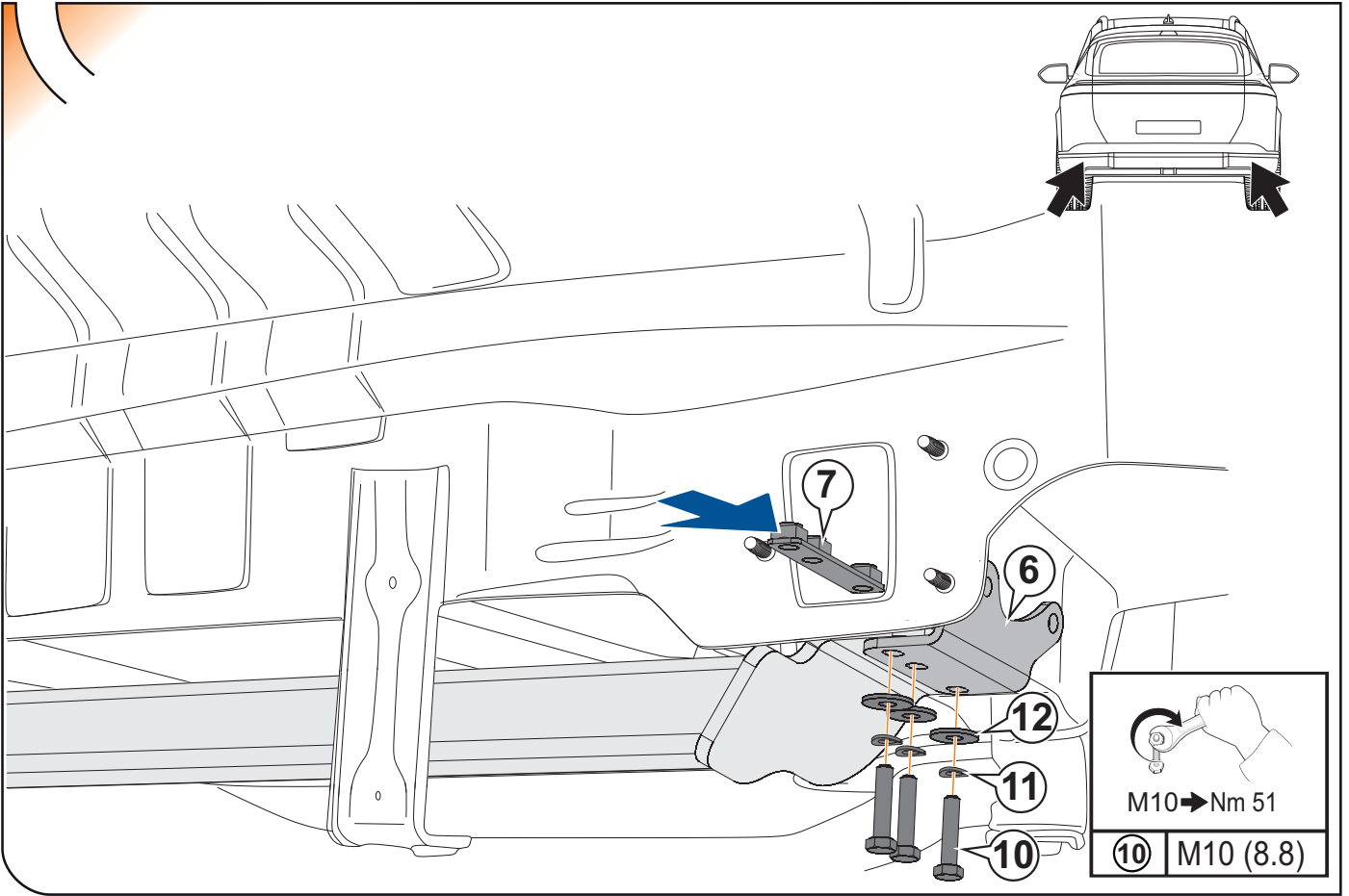

10

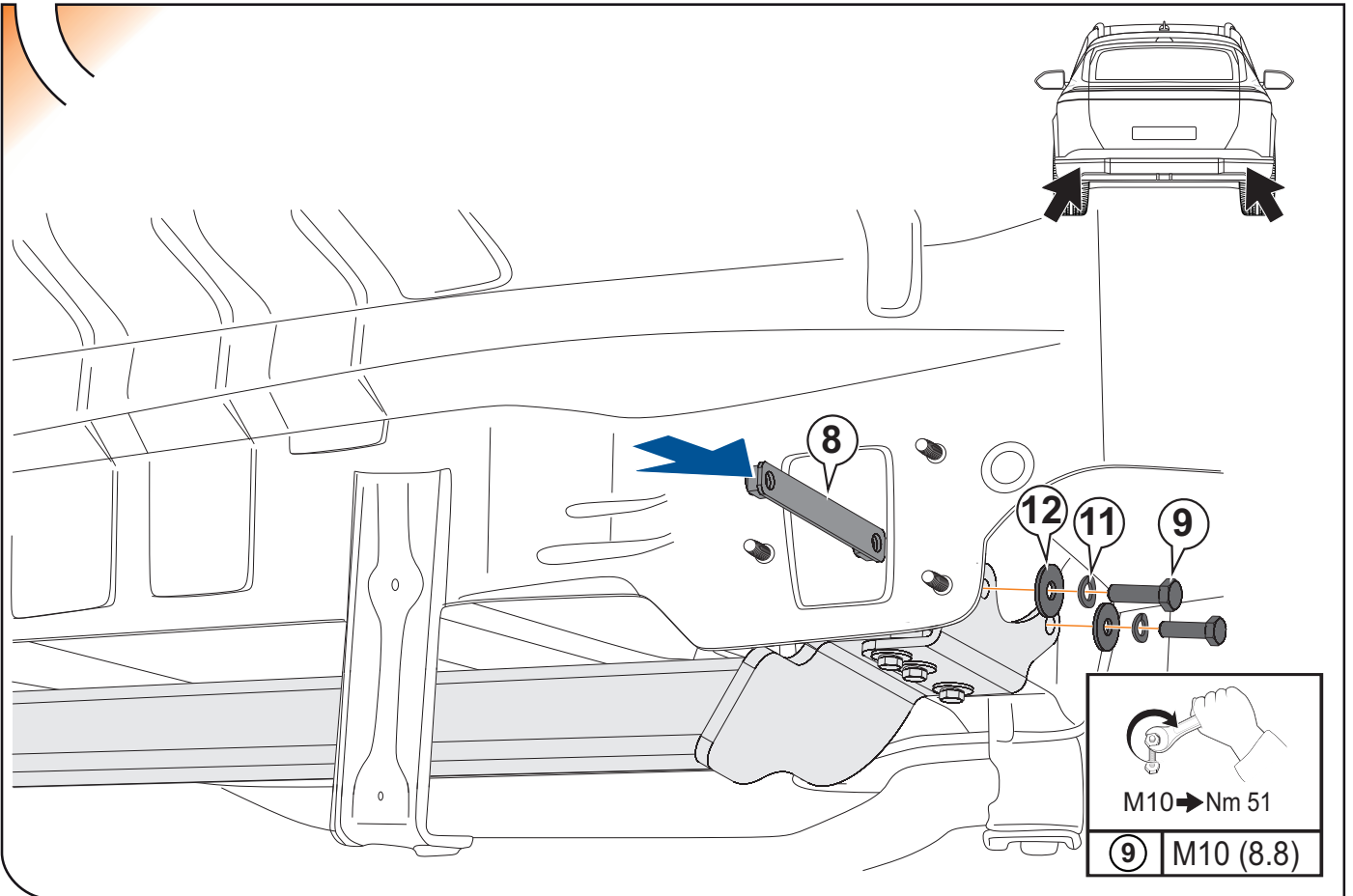



11

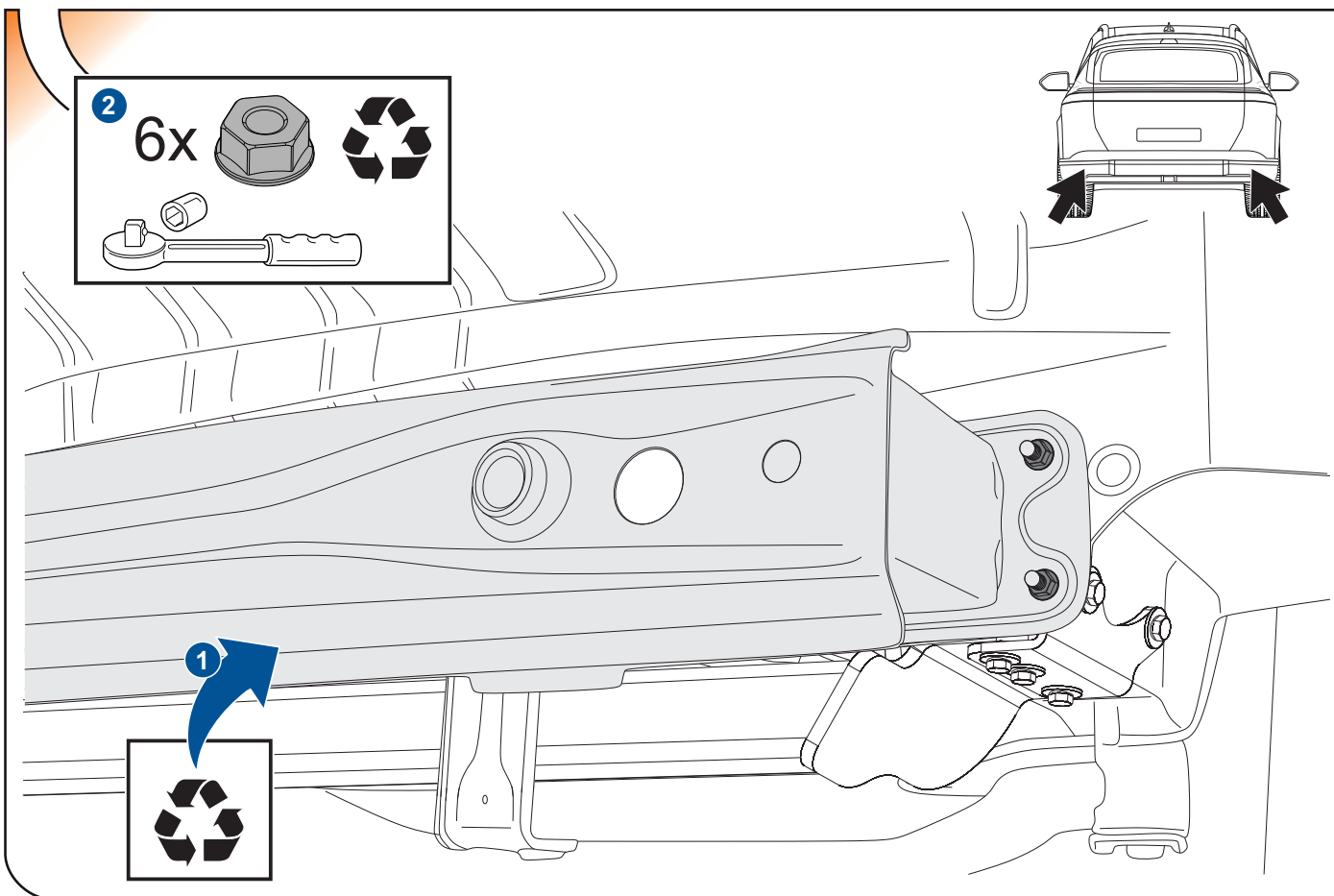

12

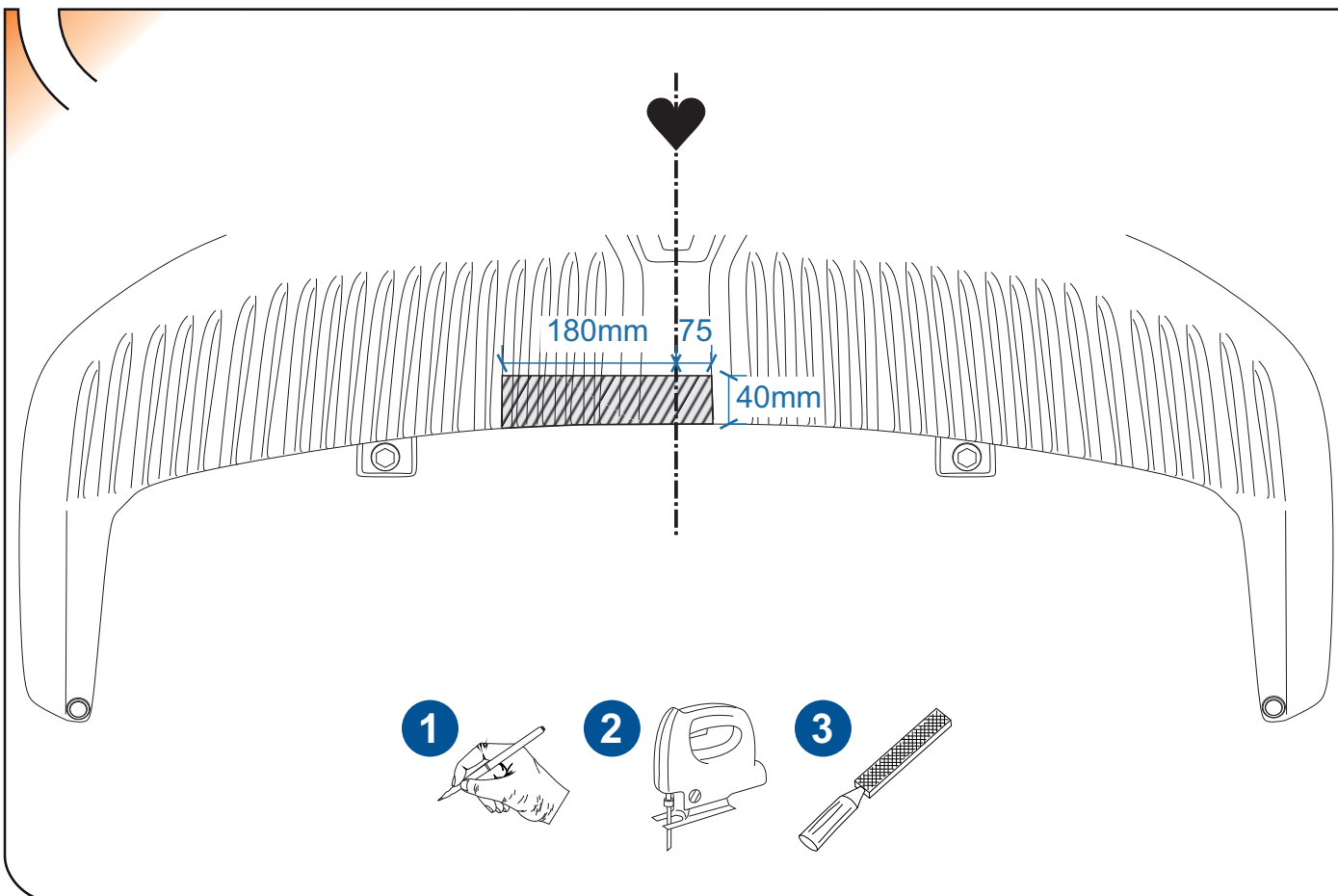

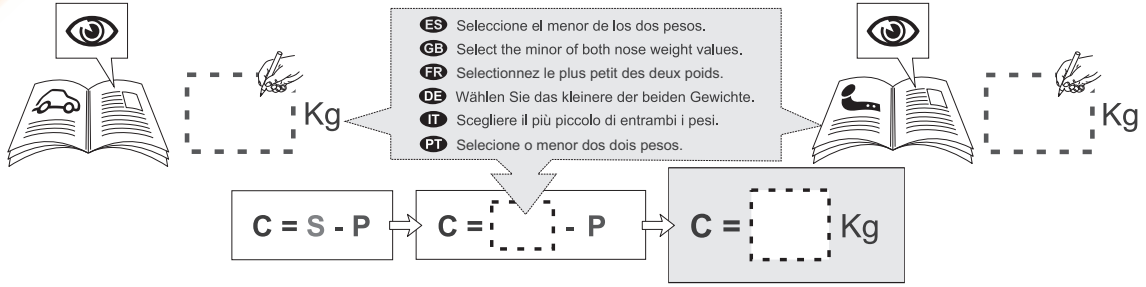

	ES	GB	FR	DE	IT	PT
C	Carga útil	Payload	Poids maximum	Nutzlast	Carico utile	Carga útil
S	Carga vertical	Nose load	Charge verticale	Stützlast	Carico verticale	Carga vertical
P	Peso en vacío	Unladen weight	Poids net	Leergewicht	Peso vuoto	Peso vazio
W	Peso total en el centro de gravedad	Total weight at the centre of gravity	Poids total au centre de gravité	Gesamtgewicht im Schwerpunkt	Peso totale nel centro di gravità	Peso total no centro de gravidade

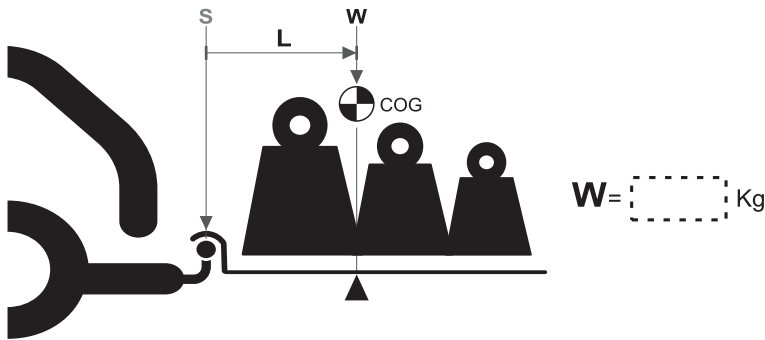

S \ L	0	200 cm	400 cm	600 cm	800 cm
40 kg	40 kg	40 kg	40 kg	30 kg	20 kg
60 kg	60 kg	60 kg	60 kg	45 kg	30 kg
80 kg	80 kg	77,5 kg	75 kg	57 kg	37,5 kg
100 kg	100 kg	88 kg	75 kg	57 kg	37,5 kg
120 kg	120 kg	100 kg	75 kg	57 kg	37,5 kg
140 kg	140 kg	110 kg	75 kg	57 kg	37,5 kg

OUT

